

SERIES M2

The Series M2 embraces three models the M2-9, M2-10 and M2-12 offering pivot-stylus dimensions covering virtually all turntable requirements.

These arms offer at reasonable cost, meticulous build quality with all the most important features including lightweight stainless steel tonearm, detachable magnesium headshell with azimuth adjustment, tungsten balance weight, superb quality ball race bearings etc., and a level of stiffness and rigidity to suit all types of cartridge.

All M2 arms are equipped to receive an accessory fluid damper FD-M2.



S M E

The best pick-up arm in the world

These precision pick-up arms embody well tried SME principles and are suited to a broad range of cartridges including those of medium and low compliance.

Series M2-9 is the standard arm having a pivot-stylus dimension of 233.2 mm (9.18") and will therefore be the one most frequently used. Typical effective mass 9.5 grams.

Series M2-10 is identical except that the pivot-stylus dimension is 239.3 mm (9.42") a difference that suits the layout of some decks. Typical effective mass 9.6 grams.

Series M2-12 has a pivot-stylus dimension of 308.8 mm (12.16"). Distortion caused by lateral tracking error is at least 25% less than possible with a nine inch arm. However effective mass will be typically 12.0 grams. Also, a turntable designed for 12-inch arms must be selected.

The internally damped tonearm of highly polished stainless steel provides sparkling uncoloured reproduction.

A unique single element balance system caters for cartridges weighing 5 to 12 grams. After balancing tracking force is applied by forward movement of the weight ensuring the lowest system inertia. The weight moves on a precision screw thread with backlash eliminator allowing exact setting of vertical tracking force.

The M2 shell is pressure die-cast in magnesium for lightness and rigidity. A collet of ingenious design affords 'one-piece' rigidity and allows azimuth correction to be made before final tightening.

A fluid damper FD-M2 is an optional accessory. The normal slow passage of the arm across the record is unaffected but influences which would tend to produce over-rapid motion are resisted by the flow characteristic of the fluid. It's use is recommended with very low compliance cartridges or where there is a problem with external vibration such as a springing floor.

Dimensions

	M2-9	M2-12
	mm	mm
	Ins	Ins
Nominal length, pivot stylus (A)	233.20	308.80
Distance from bedplate centre to turntable centre (B)	215.40	295.60
Cartridge fixing centres (C)	12.70	12.70
Offset angle (D)	23.63°	17.62°
Linear Offset (E)	93.47	93.47
Overhang (F)	17.80	13.21
Height above mounting surface (G) max.	87.00	87.00
min.	63.00	63.00

Note: When the turntable surface is more than 41.30mm (1.625") above the surface on which the arm is mounted a P1 spacer, SME Part No. 3823/IV, is required.

Mounting surface to underside of headshell (H) max.	67.40	67.40
min.	43.40	43.40
Depth below mounting surface (J)	46.00	46.00
Balance weight radial clearance (K)	51.00	51.00
Tracking adjustment ±	12.70	12.70

M2-10

Nominal length, Pivot to stylus (A)	239.30	9.42
Distance from bedplate centre to turntable centre (B)	222.00	8.74
Offset angle (D)	23.23°	
Overhang (F)	17.30	0.68

All other dimensions are as M2-9.

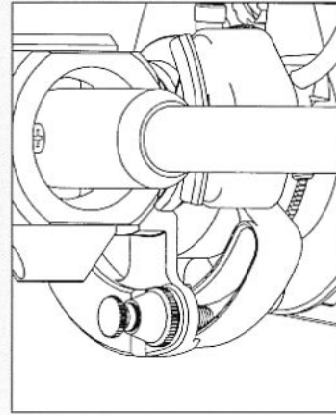

Fluid Damper
FD-M2

☆ 1.0 gram per revolution tungsten weight sub-graduated 0.25 and 0.025 gram moving on a precision screw with backlash eliminator.

☆ 1220mm (48") D501 balanced audio lead.

☆ Engineered in the best camera quality with satin chrome finish.

☆ Fluid damped lift/lower control.

☆ Geometry optimised for Ø300mm (12") LPs.

☆ Low friction, fully shielded races for both axes.

☆ Phono plugs and other contacts heavily gold plated.

☆ Pressure die-cast magnesium headshell with unique collet.

☆ Sliding base for tracking adjustment.

☆ Thin-walled stainless steel tonearm with internal damping.

☆ Thumbwheel height adjustment.

☆ Traditional pattern anti-skate.

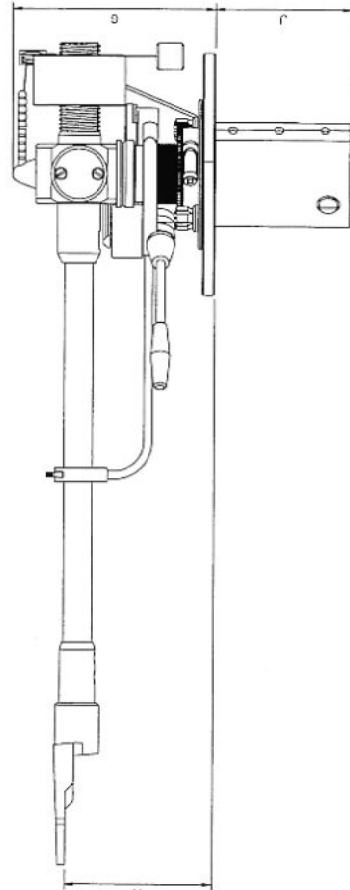
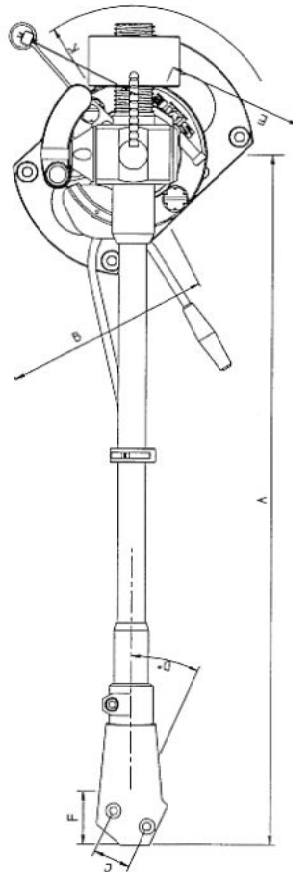

Manufactured by

SME LIMITED • STEYNING • SUSSEX • ENGLAND •  +44 (0)1903 814321 •  +44 (0)1903 814269

SME